



CONTROL ENGINEERING LABORATORY

Fuzzy modelling for a rotary dryer

Davide Fratantonio
Leena Yliniemi
Kauko Leiviskä

Report A No 18, June 2001

**University of Oulu
Control Engineering Laboratory
Report A No 18, June 2001**

Fuzzy modelling for a rotary dryer

Davide Fratantonio*, Leena Yliniemi** and Kauko Leiviskä**

* Università di Palermo, Dipartimento di Ingegneria Chimica

** University of Oulu, Control Engineering Laboratory

Abstract: In this research a fuzzy model is developed for a rotary dryer. It is applied to the pilot plant rotary dryer located in the Control Engineering Laboratory at Oulu University.

Firstly, a literature review looking at the current situation of fuzzy modelling and comparison of different methods is done. One modelling method is then applied to the building of the model from data. The rule parameters are determined on the basis of clusters created by Kohonen learning rule method and the initial model is optimised by the trial and error method. The resulting model behaviour is examined with simulation and, the results achieved are compared with other models.

Keywords: rotary dryer, fuzzy modelling, neural network

ISBN 951-42-6433-9

ISSN 1238-9390

ISBN 951-42-7511-X (PDF)

University of Oulu

Control Engineering Laboratory

Box 4300

FIN-90014 UNIVERSITY OF OULU

Contents

1	Introduction.....	1
2	Modelling of a rotary dryer.....	2
2.1	Description of the pilot plant rotary dryer	2
3	Introduction to the fuzzy modelling.....	3
4	Fuzzy modelling methods	4
4.1	Neuro-Fuzzy Method.....	4
4.2	Fuzzy clustering method.....	5
4.3	Linguistic Equation (LE) method	6
4.4	Takagi-Sugeno fuzzy model	7
5	Literature review from constrained parameter estimation.....	8
6	Applications	13
6.1	Combined cycle power plant	13
6.2	Predictive control based on fuzzy model.....	14
6.3	Model for residual stresses induced by grinding	16
7	Design procedure	17
7.1	Model structures.....	17
7.2	Extracting the initial fuzzy model	18
7.3	Initial model validation	20
7.4	Parameter optimisation	21
8	Conclusion and further developments	25
	References.....	26

1 INTRODUCTION

In the synthesis of a controller, it is very important to design a good model for a system as the aim to achieve good control. Better controller tuning and performance can be achieved from the good model of the system as opposed to the poor one. The objective of this work is to analyse and to compare different fuzzy modelling methods and to apply some selected method to the modelling of a rotary dryer.

2 MODELLING OF A ROTARY DRYER

The fuzzy modelling of a rotary dryer is a part of the larger project, which concerns with modelling and control going on in Control Engineering Laboratory. Different control strategies developed for the rotary dryer have been tested both with simulations and control experiments with a pilot plant dryer.

A dynamic mathematical model has been developed for the pilot plant rotary dryer. This model is based on simultaneous heat and transfer equations includes partial differential equations, which are complex and difficult to handle and to understand [1]. Furthermore, some parameters in the model are difficult to determine. Fuzzy models are less complex and easily understood because they are represented in the linguistic form. Fuzzy models are also easier to handle and they can be developed directly from available process data.

2.1 Description of the pilot plant rotary dryer

In the pilot plant rotary dryer the material to be dried is calcite. The material is fed to the dryer from a silo with a screw conveyor where it is watered. The length of the drier is 3 m and the diameter is 0.5 m. Drying air is supplied with a blower and it is heated by burning gases from a burning chamber. Propane gas is used as fuel. The dried product is fed back to the silo with a belt conveyor.

The detailed description of the pilot plant dryer is presented in the paper by Juuso et al. [16].

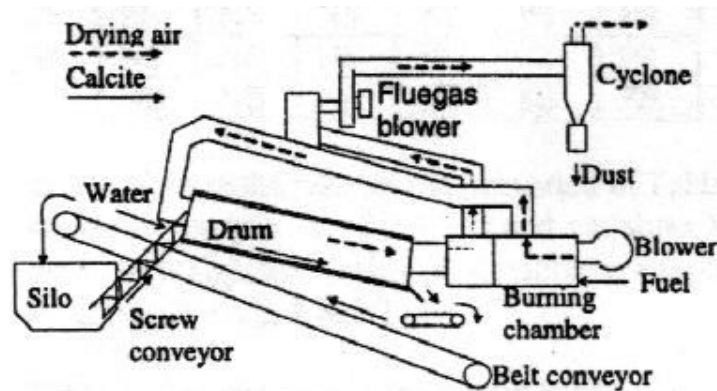

Figure 1. Structure of the pilot plant rotary dryer.

3 INTRODUCTION TO THE FUZZY MODELLING

Fuzzy modelling methods are attractive, because they can be developed from real process data with or without expert knowledge. The non-linearity can be handled efficiently, and the results presented as fuzzy rules are informative. Many methods can be found from the literature for the identification of a fuzzy model. The most common methods are fuzzy clustering methods, neuro-fuzzy method and linguistic equation (LE) method.

To construct a new fuzzy model for a given system engineers usually face the following questions [9]:

1. How to define membership functions? How to describe a given variable by linguistic terms? How to define each linguistic term within its universe of discourse and membership function, and how to determine the best shape for each of these functions?
2. How to obtain the fuzzy rule base? In modelling many engineering problems, usually, nobody has sufficient experience to provide a comprehensive knowledge base for a complex system that cannot be modelled physically, and where experimental observations are insufficient for statistical modelling. Moreover, human experience is debatable and almost impossible to be verified absolutely.
3. What are the best expressions for performing union and intersection operations? In other words, which particular function of the t-norms and s-norms should be used for a particular inference.
4. What is the best defuzzification technique for a given problem?
5. How to reduce the computational effort in operating with fuzzy sets, which are normally much slower than operating with crisp numbers?
6. How to improve computational accuracy of the model? Being fuzzy does not necessarily mean inaccurate. At least, accuracy should be acceptable by the nature of the engineering problem.

4 FUZZY MODELLING METHODS

4.1 Neuro-Fuzzy Method

The neuro-fuzzy methods [2] combine advantages from neural networks and fuzzy logic. The advantages of the neural networks are e.g. learning and generalisation. The advantages of fuzzy logic are e.g. human way of thinking (IF – THEN rules) and handling of uncertainty.

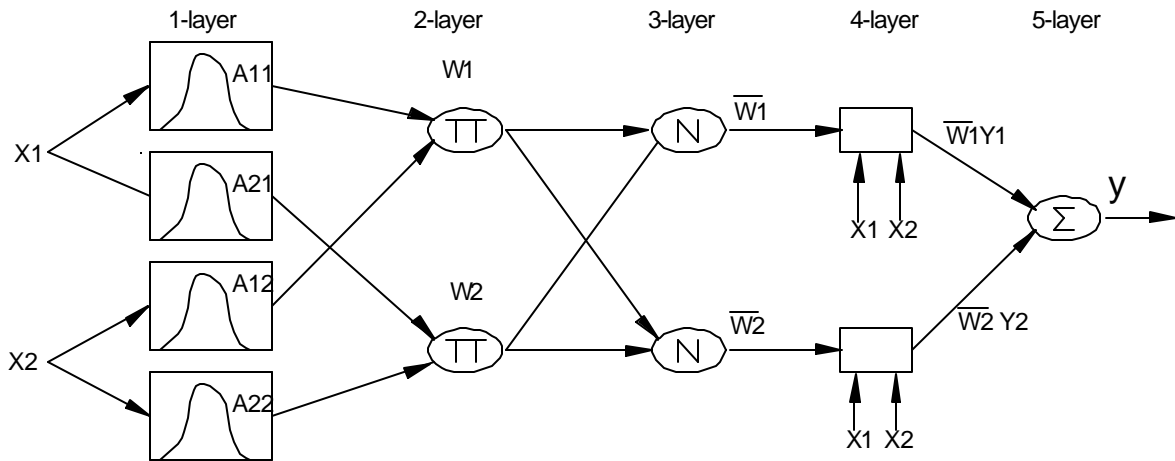

Layer 2. Nodes in this layer are calculated as the product of all incoming signals. The output at the node corresponds to the firing strength (w_i) of rule i .

Layer 3. Nodes in this layer calculate the ratio of a rule to the sum of all rules firing strengths.

Layer 4. In this layer the output value (y_i) of each node is calculated. The parameters of the function are consequent parameters.

Layer 5. The output of the network is calculated by summing the incoming signals.

Tuning is based on input-output data. In the tuning the incoming signals move from the first layer, where the parameters of the linear functions are estimated by the least squares techniques. After passing the network the error between the calculated output and real data output is calculated. In the backward-pass the parameters of the nodes (parameters of the membership functions) in the first layer are optimised by the

gradient descent algorithm. Initial rules and membership functions are developed from the expert knowledge or by using some simple fuzzy clustering algorithm.

4.2 Fuzzy clustering method

In clustering, a data set $Z = (z_1, z_2, \dots, z_N)$ of objects are portioned into natural subsets or clusters. The objects have properties or features, which distinguish them from the members of the other clusters [19]. In the fuzzy clustering these subsets are fuzzy sets. Centres of the clusters v_i are identified by the fuzzy clustering algorithms. Each data point belongs to a cluster with some membership degree μ_{ik} . The purpose of many fuzzy algorithms is to minimise some objective with respect to the fuzzy memberships μ_{ik} and cluster centres v_i .

The most common algorithm is fuzzy c-means algorithm [20]. The purpose of this algorithm is to minimise the objective function J_m :

$$J_m = \sum_{k=1}^n \sum_{i=1}^c (\mu_{ik})^m D_{ik}^2 \quad (1)$$

where the measure of dissimilarity $D_{ik} = |z_k - v_i|$ denotes the distance (Euclidean distance) between the data point z and the cluster centre v_i , $m(>1)$ is fuzziness parameter and c is the number of the clusters.

In the beginning of the algorithm the memberships μ_{ik} are initialised with random number [0,1] so that the following condition holds

$$\sum_{i=1}^c \mu_{ik} = 1 \quad (2)$$

Algorithm iterates ($l=1,2,\dots$) as follows($c \geq 2$):

1. The cluster centres are updated by the equation
2. The memberships are updated by the equation

$$v_i = \frac{\sum_{k=1}^N (\mu_{ik})^m z_k}{\sum_{k=1}^N (\mu_{ik})^m} \quad (3)$$

$$u_{ik} = \frac{1}{\sum_{j=1}^c \left(\frac{D_{ik}}{D_{jk}} \right)^{\frac{2}{m-1}}} \quad (4)$$

3. If $|D^{l+1} - D^l| < \epsilon$, then stop, else go back to the stage 1.

The algorithm proceeds to the local minimum, so the v_i 's may differ when repeated. By using the Euclidean distance norm, the geometrical shape of the clusters is spherical (Figure 3a). However, this shape is not practical in real data sets. For example, in the real process data sets the shapes of the clusters are more like ellipsoidal, linear, etc. (Figure 3b). Also in the same data set Z , the shape of different

clusters may have different variations in the clusters shape. In the fuzzy c-means algorithm this can be handled by using adaptive distance norm.

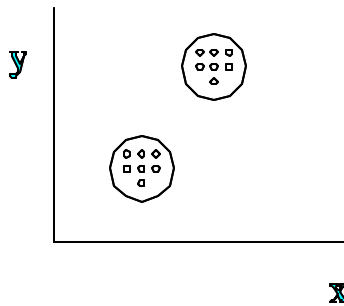

Figure 3a. Spherical cluster [2]

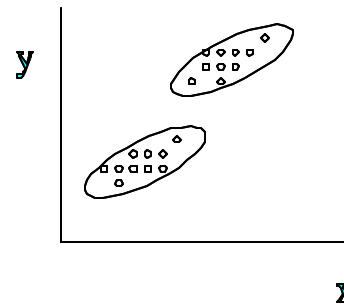

Figure 3b. Example of shapes in real datasets [2].

The centre point v_i of the cluster represents the centre of a fuzzy rule. So the number of the rules is the same as the number of the clusters c . The common choice for the rule is Takagi-Sugeno type, where the consequent parts of the rules are linear functions. Their parameters are estimated by the least squares techniques. Antecedent membership functions of the rules can be extracted from the μ_{ik} 's for example by projection (Figure 4)

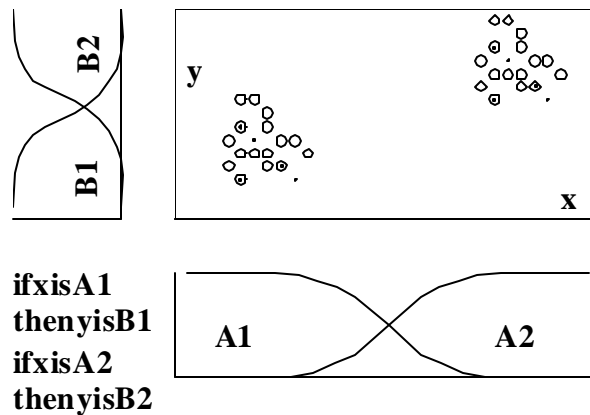

Figure 4. The idea of the fuzzy clustering [2].

4.3 Linguistic Equation (LE) method

In fuzzy linguistic system models, the traditional equation-based input-output relationship is replaced by a set of logical IF-THEN rules with vague predicates [3]. IF-THEN rules of a fuzzy model describe the linguistic values of the process-output for given linguistic values of the process-input and process-state variable. Fuzzy models are used mainly in fields concerned with fuzzy control. It seems natural to use models in problems handled with fuzzy logic because of the overall “inexact” nature of those problems.

The modelling procedure is connected with expert knowledge. The structure identification (determination of input and output variables, number of rules in the rule base, partitioning into fuzzy sets,...) is claimed to be more an art than a science and therefore automatic methods do not seem to be useful.

The main steps of the fuzzy modelling are:

1. Selection of the input, state, and output variables
2. Determination of the universe of discourse
3. Determination of the linguistic labels (reference fuzzy sets) into which these variables are partitioned
4. Formation of the set of linguistic rules that represent the relationships between the system variables
5. Selection of the appropriate reasoning mechanism for the formalisation of the fuzzy model
6. Evaluation of the model adequacy.

The above steps can be found in almost every case, but the overall importance of an individual step may vary from case to case. For example, efforts needed to form the rule base (step 4) depend on the overall difficulty in understanding the behaviour of a process, and on the necessity and possibility to use different knowledge sources.

Automatic tuning or identification has in many cases proven to be useful. However the installation of an automatic identification method can be a difficult task. The stability of such method can be impossible to prove, which may result in difficulties when critical processes are controlled.

4.4 Takagi-Sugeno fuzzy model

Fuzzy models can be divided into two classes. In the first class of fuzzy models the rules have fuzzy antecedent part and fuzzy consequence part as follows

$$R^i : \text{IF } z_1 \text{ is } A_1^i \text{ AND } \dots \text{AND } z_n \text{ is } A_n^i \text{ THEN } y \text{ is } C^i ,$$

where R^i denotes the i th fuzzy rule, A_n^i and C^i are fuzzy sets, z_n is an input variable and y is an output variable.

In the second class of fuzzy models the rules have fuzzy antecedent part and consequence parts are mathematical functions of inputs as follows

$$R^i : \text{IF } z_1 \text{ is } A_1^i \text{ AND } \dots \text{AND } z_n \text{ is } A_n^i \text{ THEN } y^i = a_0^i + a_1^i z_1 + \dots + a_n^i z_n ,$$

where y^i is an output of the i th rule and a_n is a consequent parameter. Models of these types are called **Takagi-Sugeno** models.

5 LITERATURE REVIEW FROM CONSTRAINED PARAMETER ESTIMATION

Babuska et al. [4] describe an algorithm for incorporation of a priori knowledge into a data-driven identification for dynamic fuzzy models of the Takagi-Sugeno type. Knowledge about the modelled process such as its stability, minimal or maximal static gain, or the settling time of its step response can be translated into inequality constraints on the consequent parameters. By using input-output data, optimal parameter values are then found by means of the quadratic programming. The proposed approach was successfully applied to the identification of a laboratory liquid level process.

In the paper written by Setnes et al. [5] a Takagi-Sugeno fuzzy model with linear consequents is used to model the algae growth in lakes. Both the membership functions in the premise and the consequent parameters are estimated from measurement of relevant quantities by means of the product-space fuzzy clustering. To enhance the interpretability of the model, similarity analysis is applied and similar fuzzy sets and rules are combined, giving a transparent and compact model without notably altering the accuracy.

This paper describes the modelling of the chlorophyll concentration in lake ecosystems in the Netherlands using the TS fuzzy model with linear consequents. The identification is based on fuzzy clustering in the product space of inputs and outputs, and the identification data consist of measurements taken from nine different lakes. The advantage of this approach is that it provides a complete description of the system in term of its local characteristic behaviour in region of the data identified by clustering. Each such region defines a fuzzy if-then rule in the rule base.

Correct specification of the number of clusters is of importance. Too many clusters result in an unnecessarily complicated rule base, while too few clusters result in a poor prediction performance. Cluster validity can give an indication about the goodness of the obtained fuzzy partition. However, for complex system, identification by means of clustering are typically results in a rule base weak semantic properties. To overcome this problem, the rule base is simplified and reduced by means of similarity analysis of the antecedent fuzzy sets. Similar fuzzy sets and rules are combined, providing a semantically more tractable rule base, making it easier to assign qualitatively meaningful linguistic terms to the fuzzy sets.

In the paper written by Salehfar et al. [6] linguistic fuzzy modelling is addressed, and they propose a new systematic and simple algorithm to build and tune models directly from the input-output data. The new algorithm is called the Linguistic Fuzzy Inference (LFI) model. Like ANFIS (adaptive neuro-fuzzy inference system) the new algorithm takes advantages of neural network training techniques and it uses projection methods to build the fuzzy rules. The new algorithm consists of two procedures. The first one is for fuzzy structure identification, in which the inputs, membership functions and fuzzy rules are determined. The second one is for fuzzy parameter identification, in which training algorithms are used to tune the parameters of the membership functions.

To illustrate the validity of the proposed algorithm, three functions are tested. Due to its highly variable characteristics, the *Sinc* function is a typical benchmark for identification. The second test function is a two-dimensional non-linear static map. The third one is the Machey-Glass chaotic time series generated by an underlying non-linear dynamic system.

A new algorithm to build linguistic fuzzy models directly from input-output data is introduced. The proposed method is simple because of its pure linguistic nature. It uses symmetric triangular membership functions and a simplified fuzzy reasoning method. This algorithm can achieve either the same or better level of accuracy compared to ANFIS.

Sinc function, the proposed LFI model proved superior to the three different ANFIS algorithms. Although the Takagi-Sugeno model is generally more descriptive than the pure linguistic model, sometimes it seems that it indulges into the insignificant details of the system while the LFI model always retrieves the most important characteristics of the systems. Compared with the methods presented by Emami [17] & Sugeno [18] as the aim to build pure linguistic models, the LFI model is much simpler both in computation and in form.

Castillo and Melin [7] describe a new method for modelling complex dynamical system based on the use of a new fuzzy inference system for differential equations. It is well known that formulating a unique sufficiently accurate mathematical model for a complex dynamical system (over a whole region of discourse) may be very difficult or even impossible in some cases. The new fuzzy inference system uses differential equations as consequents in the rules, instead of simple polynomials. The new fuzzy inference system can be considered as a generalisation of Sugeno's original inference system, because the authors are modelling a particular problem by using the appropriate differential equation for each region of the domain. A typical rule in this case has the form

If x is A and y is B then $dz/dt = f(x,y)$

where A and B are fuzzy sets in due antecedent, while $dz/dt = f(x,y)$ is a crisp differential equation in the consequent. Usually $f(x,y)$ is a non-linear function of the input variables x and y , and this means that we have a non-linear differential equation in the consequent. This new fuzzy inference system reduces to the standard Sugeno system only when the differential equations have closed form solution in the form of polynomials. However, the solutions of the differential equations can be more complicated analytic functions or in most cases the solutions are so complex that can only be approximated by numerical methods. The advantage of this generalisation of Sugeno's original method is that, in general, we can represent more complicated dynamic behaviours and also because of this fact, the number of the rules needed to represent a given dynamical system is smaller.

Hwang [8] presents an approach to automatic design of the optimal fuzzy rule base for modelling and control using evolutionary programming. Evolutionary programming simultaneously evolves the structure and the parameter of the fuzzy rule base. Since they are codependent, simultaneous evolution with no predefined assumption about rule base structure can result in a more appropriate rule base for a

given task. In the design of a fuzzy model and fuzzy controller, a major difficulty is encountered in the identification of the optimal fuzzy rule base. This study has presented an approach to evolutionary design of fuzzy rule base structure in order to eliminate the difficulty.

Ali and Zhang [9] present a systematic approach to the modelling of engineering systems using a fuzzy formulation that is independent of human knowledge. The algorithm presented in the paper can be viewed on one hand as an extension and improvement on the fine-tuning approaches in others works. On the other hand, it can be viewed as a surface-fitting technique, where huge computational power is used to fit experimental data over a very complex hyperspace of very large dimension. It can also be viewed as an explicit formulation of what is otherwise implicit in the adaptation process of a back-propagation neural network. However, the main objectives of the algorithm are:

1. Automatic generation of fuzzy rules that are not biased by human factors or context-dependent experience
2. Provision of clear *physical* meaning of each linguistic term or fuzzy set without any a priori knowledge about the system.
3. Establishment of clear systematic procedure for constructing a fuzzy model, where trial and error is minimised.

The algorithm described in this paper was developed in two versions. The first version was implemented using Turbo Pascal for Windows and runs on a PC. For a Pentium 166 MHz processor with 8Mbytes free RAM, this program is capable of optimising models with up to nine variables, and up to five linguistic terms for each variable. The second version was implemented on a Connection Machine CM5 computer, and was written in C* - a data-parallel dialect of standard C.

Vachkov and Fukuda [10] present a concept of multilevel fuzzy modelling. In their paper the problem of fuzzy models learning and accuracy is viewed in another way i.e. by the specially proposed multilevel composite fuzzy model CFM. It is an additive structure of one main fuzzy model and a number of correction models that try to gradually decrease the total approximation inference error. It is also shown that such a strategy is able to update the model when a new data set is available still keeping the former relationships.

The proposed multilevel fuzzy modelling approach is performed as a sequence of $(k+1)$ identification procedures of one main fuzzy model and k correction fuzzy models. The final accuracy of this modelling approach depends on the particular identification accuracy of each submodel used.

The multilevel fuzzy modelling could be used as one possible approach to decreasing the total number of parameters of the fuzzy model by its decomposition of a series of simpler fuzzy models.

The main characteristics (features) of the multilevel composite fuzzy model CFM can be expressed as follows:

1. If one data set D is only used for fuzzy modelling the CFM is able to gradually improve the modelling accuracy by adding another level model, namely the correction model.
2. If different data sets $D, D_1, D_2 \dots$ are available at different time the concept of CFM can be used for updating (evolving) the previous available fuzzy model by adding another correction model, but the new data set. This strategy gives a general possibility to update the overall model behaviour according to the new process information while still keeping the behaviour learn by the previous data set.
3. Finally the multilevel structure of the proposed model as shown in Figures 5 and 6, could be utilised even with different types of models, not necessarily only fuzzy models. This could be the case when the basic level model is a kind of analytical or stochastic model and the other (correction) level models are fuzzy models learnt from the next available data sets.

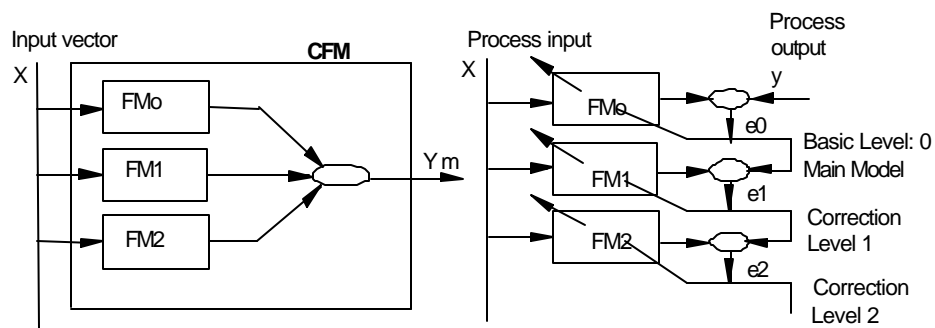

Fi

Li
in
m
bc
su
in
be
fu
m

show that the proposed method can provide good model structures for fuzzy modelling and has high computing efficiency.

Park et al. [12] present an approach, which is useful for the identification of a fuzzy model. The identification of a fuzzy model using input-output data consists of two parts: structure identification and parameter identification. In this paper, algorithms to identify those parameters and structures are suggested to solve the problems of conventional methods. Given a set of input-output data, the consequent parameters are identified by the Hough transform and clustering method, which considers the linearity and continuity, respectively. For the premise part identification, the input space is partitioned by a clustering method. The gradient descent algorithm is used to

fine-tune parameters of a fuzzy model. Finally, it is shown that this method is useful for the identification of a fuzzy model by simulation.

Huang and ChiChu [13] propose to exploit both gray relational analysis and data transformation techniques to simplify the modelling procedures. The transformation method allows us to map the original data to other domains such that there is no need to adjust the membership functions and the fuzzification process is simply taking place on the fixed ones. Since too many system variables involved may complicate the fuzzy modelling, the gray relational method is exploited to select the crucial variables from a finite set of candidates. Based on the calculated relational degrees between the output and the prospective input variables, we can decide which are the important premise variables. The proposed methods have definite effects on the model's performance; therefore, the way to systematically adjust the transformation functions is also investigated. Ease in selecting the premise variables and minimal effort needed to adjust system parameters are the merits of the proposed work. Simulation results from two different examples are presented to demonstrate the superiority of the proposed model to the conventional methodologies.

6 APPLICATIONS

6.1 Combined cycle power plant

Sáez and Cipriano [14] present a new identification method using a sensitivity analysis to determine the relevant input variables of a fuzzy model. As an example, fuzzy models for a combined cycle power plant are developed from real time data. Considering the growing importance of thermal power plants, this work proposes, as a first step to improve the efficiency of power plant boilers, to develop models of these equipments in order to design automatic control algorithms that reduce their operational costs.

Due to the highly non-linear behaviour of thermal power plants boilers, non-linear models are necessary to represent the process operation. In this case, fuzzy non-linear models are used. As further work, these models will be used to design an economical optimal control strategy based on minimisation of thermal power plant operation costs.

The main steps of a model identification procedure on fuzzy logic are presented in Figure 7. First, it is necessary to select real date coming from the process. The data include enough information to represent the different normal operation conditions of the process. Next, the premises and consequences parameters of fuzzy models are determined using fuzzy clustering and least squares. Then the relevant input variables of the fuzzy models are selected. After that, the premises and consequence parameters

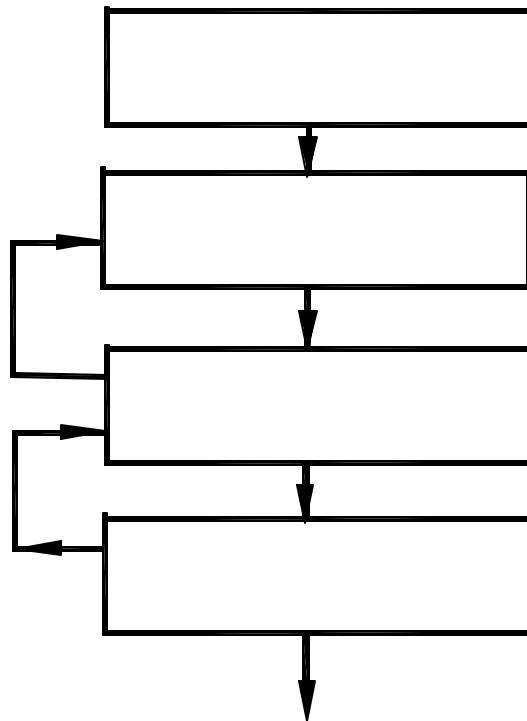

The fuzzy model is evaluated using a validation set. Then in the adjusted model evaluation is appropriate, the model identification procedure finishes, otherwise it is convenient to review the relevant variable selection to find if any important variable is not included.

6.2 Predictive control based on fuzzy model

In recent years, the predictive control has become a very important area of research. It is based on the prediction of the output signal at each sampling instant. The prediction is obtained implicitly and explicitly according to the model of the controlled process. Using the actual predictive control law, the control signal is calculated which forces the predicted process output signal to follow to the reference signal in way to minimise the difference between the reference and the output signal in the area between certain time horizons.

Skrjanc and Matko [15] present a new method for predictive control. This approach combines a well-know method of predictive functional control together with fuzzy model of the process. The prediction is based on a global linear model, which includes the fuzzy model given in the form of Takagi-Sugeno.

The controllers on the prediction strategy also exhibit remarkable robustness with respect to model mismatch and unmodelled dynamics. The proposed fuzzy predictive control has been evaluated by implementation on **heat exchanger plant**, which exhibits a strong non-linear behaviour.

The development of a new fuzzy predictive scheme was motivated by the unsatisfactory results obtained by using conventional techniques. Regarding to the real time experiments realised on the heat exchanger plant, it can be seen that the novel algorithm introduces a great robustness and satisfactory performance also in the presence of model parameters mismatch, which was obtained by change of the outlet flow. The proposed approach offers some advantages in the case of non-linear system with simple dynamics.

Rauma [3] presents the construction of a simple fuzzy model for a chemical process. The fuzzy model is used in a model-based fuzzy control system to produce a prediction of the behaviour of a **gas purification process**.

Sulphur dioxide gas is purified in two-stage purification process. In the first stage the gas is cooled to about 200°C. In the second stage the gas is then purified with sulphuric acid.

The main temperatures of the gas purification process were modelled to acquire knowledge about the process. Four temperatures were modelled, and these included temperatures of gas, sulphuric acid and water. Each temperature was modelled separately. So the overall fuzzy process model consists of many partial fuzzy modules.

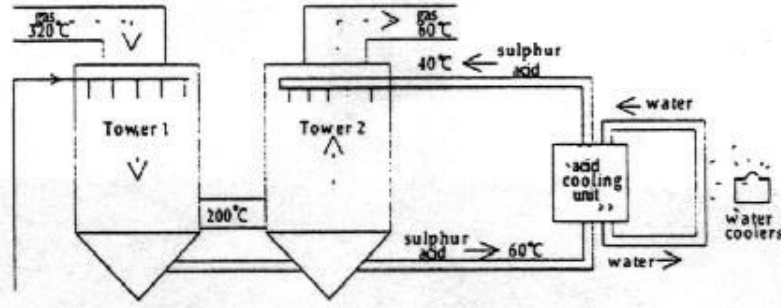

Figure 8. Gas purification process.

The basic fuzzy control system was adapted with a model-based part to achieve better control results than with the basic one. The main idea was to add a predictive feature to inference performed by the existing fuzzy control system to take several minutes delay into account.

The fuzzy model was set to predict the behaviour of the temperature of the gas. The output of the model was connected to a fuzzy controller similar to that installed before. After installing the model based part of the control system, two similar fuzzy logic controllers; one using the measured change in the temperature and the other using the estimated change in the temperature. The conventional and the model-based controller were set to work in parallel, and their control outputs were summed. The final structure of the control system is presented in Figure 9.

In this case the advantage of the structure used is that it enabled building the control system piece by piece. The basic controller was tuned manually earlier and the new part of the system did not affect the basic controller's function.

The results shown in Figure 10 present the behaviour of the temperature of the gas before installing the basic fuzzy control system and the same measurement after installing normal with the

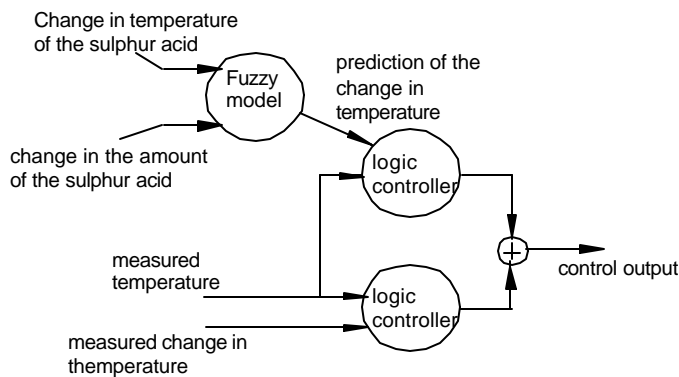

Fig

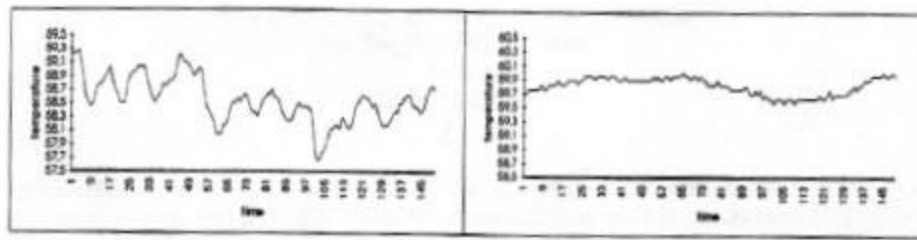

Figure 10. Temperature of the gas before installing the control system (on the left) and after installing the basic control system (on the right).

6.3 Model for residual stresses induced by grinding

Ali and Zhang [9] present an example about the modelling of a grinding process. Grinding is one of the most complex manufacturing engineering problems, which involves a large number of variables and physical processes that are non-linear and interdependent. Quality grinding still depends to a great extent on skilled machine operators who use rules-of-thumb based on many years of trial-and-error experience. However, modern complex surface requirements, such as induced residual stresses, are beyond everyday experience of skilled operators. Then, there is a need to generate fuzzy rules from experimental observation alone. Therefore, grinding is a process that can benefit greatly from fuzzy modelling.

The process can be modelled in the implicit form

$$S = f(T, W, D) \quad (5)$$

where T is table speed, W is wheel speed, and D is the depth of the cut. They are the major independent variables affecting the output S, residual stresses.

The author's algorithm accepts a text file as an input, see Figure 11 [9]. Each line marked with “**” defines a variable in terms of its name, the universe of discourse, and the number of linguistic terms used in describing this variable. Each variable is followed by the definition of its linguistic terms, marked with “*”. Each term is defined by its text label, the supporting subset, and the five parameters defining the shape of its membership functions. This simple file format describes to the program the initial N parameters defining the various linguistic terms. It also provides the database from which an initial rule base is constructed. The program keeps searching for a better set of (N+1) parameters.

The superiority of the optimised model is clearly demonstrated by a great reduction in the inference error as well as the specific entropy of the rule base. The product of the model is a true representation of membership functions, for each linguistic term, and the most robust and accurate set of fuzzy rules.

7 DESIGN PROCEDURE

The above literature review shows several methods for fuzzy modelling. Our work presents an application of these methods to the pilot plant rotary dryer located in Control Engineering Laboratory at Oulu University.

The models were developed using MATLAB's Neural Network Toolbox, Fuzzy Toolbox and Simulink (appendix 1). The whole database contained 1899 observations, training data consisted of 1227 (data pairs) and testing data consisted of 671 data pairs. The data includes following variables:

1. Fuel rate [g/min]
2. Input moisture of solids $X_{s,in}$ [m-%]
3. Output moisture of solids (t-1), $X_{s,out}(t-1)$ [m-%]
4. Output moisture of solids (t), $X_{s,out}(t)$ [m-%]
5. Output temperature of solids (t-1), $T_{s,out}(t-1)$ [°C]
6. Output temperature of solids (t), $T_{s,out}(t)$ [°C]

Figure 11 presents the test data collected from the real process and Figure 12 presents the train data collected from the real process.

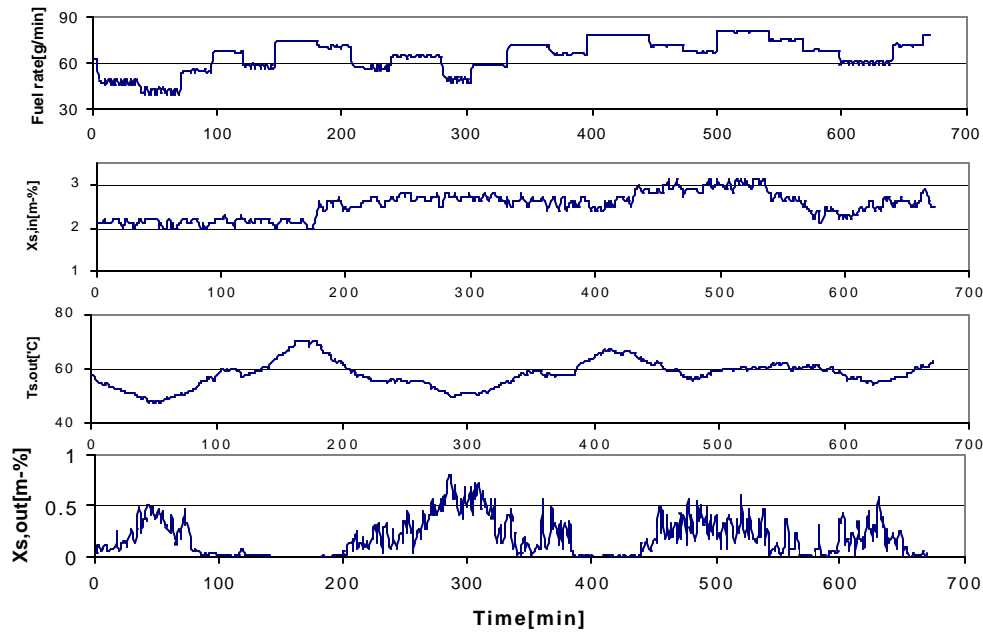

Figure 11. Testing data.

7.1 Model structures

We used two different structures, one consisted of two MISO models (Multiple Inputs and Single Output) and is shown in Figure 13a and second one consisted of only one MISO model and is shown in Figure 13b. In the first case we had a model with three inputs and two outputs, in the second case we had only one model for only one output.

The latter was done in order to reduce and simplify the model and hence improve performance.

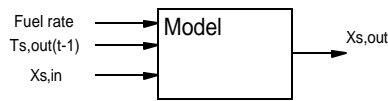
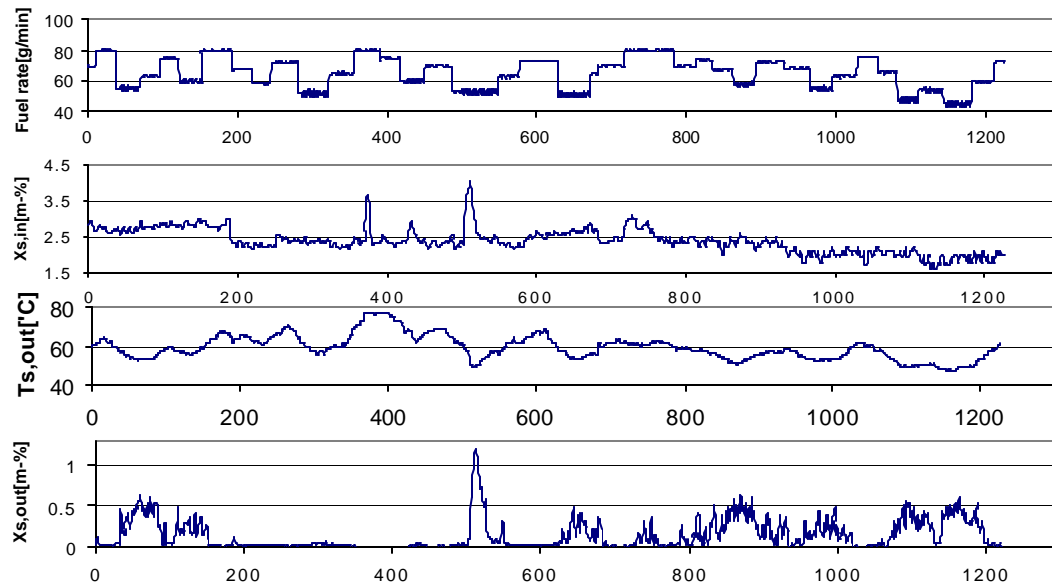

figure 15a. Structure 1.

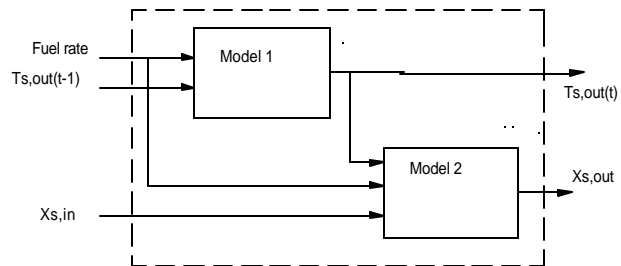

figure 15b. Structure 2.

7.2 Extracting the initial fuzzy model

Our method for extracting the fuzzy model from the obtained data is based on using a self-organising network. Such networks can learn to detect regularities and correlations in their input and adapt their future responses to that input accordingly. The neurons of competitive networks learn to recognise groups of similar input vectors.

The competitive transfer function accepts a net input vector for a layer and returns neuron output of 0 for all neurons except for the *winner*, the neuron whose weight vector is closest to the input vector.

The weights of the winning neuron are adjusted with the Kohonen learning rule. Supposing that the i^{th} neuron wins, the element of the i^{th} row of the input weight matrix are adjusted as shown below.

$${}_i\mathbf{W}^{1,1}(q) = {}_i\mathbf{W}^{1,1}(q-1) + \alpha (\mathbf{p}(q) - {}_i\mathbf{W}^{1,1}(q-1)) \quad (6)$$

The Kohonen rule allows the weights of a neuron to learn an input vector, and because of this it is useful in recognition applications. Thus, the neuron whose weight vector was closest to the input vector is updated to be even closer. The result is that the winning neuron is more likely to win the competition the next time a similar vector is presented and less likely to win when a very different input vector is presented. As more and more inputs are presented, each neuron in the layer closest to a group of inputs vectors soon adjusts its weight vector toward those input vectors. Eventually, if there are enough neurons, every cluster of similar input vectors will have a neuron that outputs 1 when a vector in the cluster is presented, while outputting a 0 at all other times. Thus, the competitive network learns to categorise the input vectors it sees.

The clustering produced p units can be viewed as p data clusters centred at $\mathbf{W} = \{\mathbf{w}_1, \mathbf{w}_2, \mathbf{w}_3, \mathbf{w}_4\}$. Each cluster centre $\mathbf{w}_i = (\mathbf{w}_{i1}, \mathbf{w}_{i2}, \mathbf{w}_{i3}, \mathbf{w}_{i4})$ is in essence a prototypical data point that exemplifies a characteristic input/output behaviour of the our system. Hence each cluster centre can be used as the basis of a rule that describes the system behaviour.

Consider a set of p cluster centres $\{\mathbf{w}_1, \mathbf{w}_2, \mathbf{w}_3, \mathbf{w}_4\}$ in 4-dimensional space. In the case of MISO system, each vector \mathbf{w}_i can be decomposed into two component vector x_i^* . And y_i^* . The cluster centre vector can be denoted as:

$$C_i = [x_i^* \quad y_i^*], \text{ where}$$

$$x_i^* = (x_{i1}^*, x_{i2}^*, x_{i3}^*) = (\mathbf{w}_{i1}, \mathbf{w}_{i2}, \mathbf{w}_{i3}),$$

$$y_i^* = \mathbf{w}_{i4}.$$

We consider each cluster centre $c_i = (x_i^* \quad y_i^*)$ as a fuzzy rule that describes the system local behaviour. Intuitively, cluster centre c_i represents the rule “if input is around x_i^* . Then output is around y_i^* ”.

We clustered our data with several cluster parameters and for each cluster we extracted one fuzzy model with the following form:

$$R_i : \text{if } x_1 \text{ is } A_{i1} \text{ and } x_2 \text{ is } A_{i2} \dots \text{ and } x_m \text{ is } A_{im} \text{ Then } y \text{ is } B_i$$

Here R_i denotes the i th rule, $i=1,2,\dots,p$; $j=1,2,\dots,m$, A_{ij} is a gaussian membership function in the i th rule associated with the j th input and B_i is a singleton in the i th rule associated with the j th output. For the i th rule, which is represented by cluster centre c_i , A_{ij} and B_i are given by

$$A_{ij} = \mu_{ij} = \exp\left\{-\left(\frac{x_j - x_{ij}^*}{\sigma_{ij}}\right)^2\right\}, \quad B_i = y_i^* .$$

7.3 Initial model validation

In order to extract the initial model, several clusterings have been done. We chose four different numbers of clusters (5, 10, 15, 20) and two different values of α . These initial models are compared with respect to the performance index:

$$PI = RMSE = \sqrt{\frac{1}{N} \sum_{i=1}^N (y_i^* - y_i)^2} \quad (7)$$

Where y_i^* is the model's output, y_i is the real output, and N is the number of data points.

Table 1. Results of the structure 1.

Description		RMSE	
Clusters	α	Training	Testing
5	0.1	0.1690	0.1590
5	0.8	0.1738	0.1447
10	0.1	0.1909	0.1682
10	0.8	0.1809	0.1561
15	0.1	0.1600	0.1311
15	0.8	0.1419	0.1073
20	0.1	0.1720	0.1600
20	0.8	0.1432	0.1354
Linear model		0.1318	0.1222

The models are also compared with the linear model:

$$X_{s,out} = 1.0052 - 0.0028 * \text{Fuel} + 0.1833 * X_{s,in} - 0.0189 * T_{s,out} \quad (12)$$

Table 1 shows the results for the structure 1 and table 2 shows the results for the structure 2.

Table 2. Results of the structure 2.

Description			RMSE	
Clusters	α		Training	Testing
10	0.1	Ts,out	1.5383	1.0473
		Xs,out	0.1516	0.1780
10	0.8	Ts,out	1.7837	1.3057
		Xs,out	0.1538	0.1775
15	0.1	Ts,out	1.4943	0.9981
		Xs,out	0.1417	0.1795
15	0.8	Ts,out	1.4915	1.2924
		Xs,out	0.1517	0.1510
20	0.1	Ts,out	1.2489	1.3215
		Xs,out	0.1556	0.1532
20	0.8	Ts,out	1.2113	1.2543
		Xs,out	0.1455	0.1439

7.4 Parameter optimisation

As mentioned, we have already completed the structure identification and obtained the initial model parameters. With these parameters, we can build the fuzzy model with the c rules. To obtain satisfactory modelling accuracy, it is better to optimise the model parameters under the performance index. There are several methods for parameter optimisation. If the membership functions in the antecedent are fixed, the consequent parameters can be optimised simply by the least squares estimation. The antecedent parameters can be optimised by applying a gradient descent method.

Here, we adopt the trial and error approach, to optimise the parameter σ_{ij} under the performance index RMSE and we added further rules to improve the model locally.

We executed this procedure only for the “winner” model (see Table 1) and after several trial and error loops we obtained using the following results:

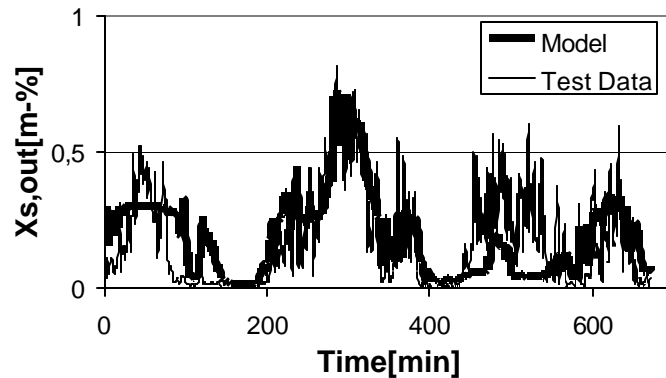

Figure 14. Initial model.

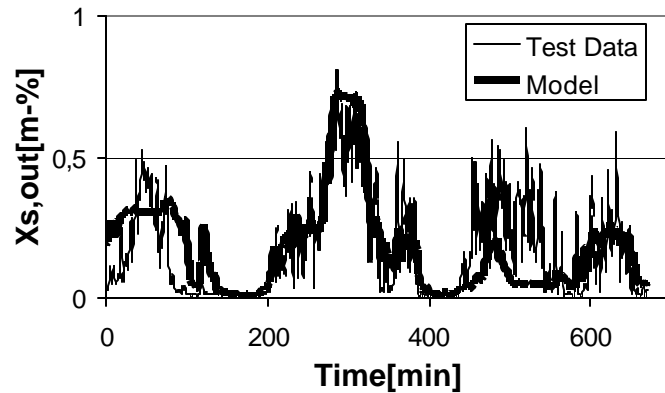

Figure 15. Optimised model.

Figure 14 shows the results for the initial model and Figure 15 shows the results for the first optimised model (15 rules), after we added other four rules to this model in order to correct the behaviour in some zones. The results are shown in Figure 16 and the RMSE values in Table 3. The parameters of the final model and the four rules added are presented in the appendix 3.

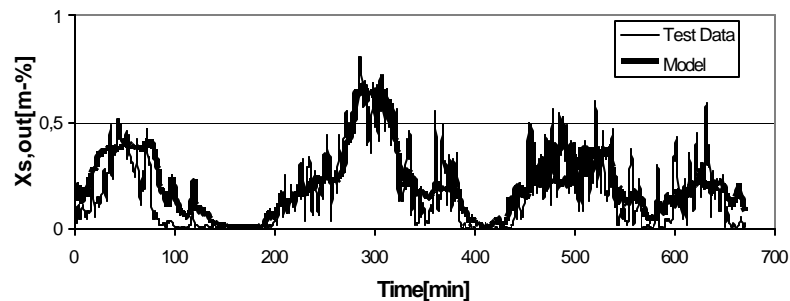

Figure 16. Final model.

Table 3. RMSE values for the new model.

Model	RMSE	
	Training	Testing
Optimised model	0.0912	0.1364
Final model	0.0818	0.1116

For the second structure we proceeded in the same way, but we used larger number for the trial and error loops. The Figures 17 and 18 show the comparison between initial model output (see Table 2) and the test data. The Figures 19 and 20 show the comparison between final model output and the test data after the parameter optimisation and with one more rule. The RMSE results are present in Table 3.

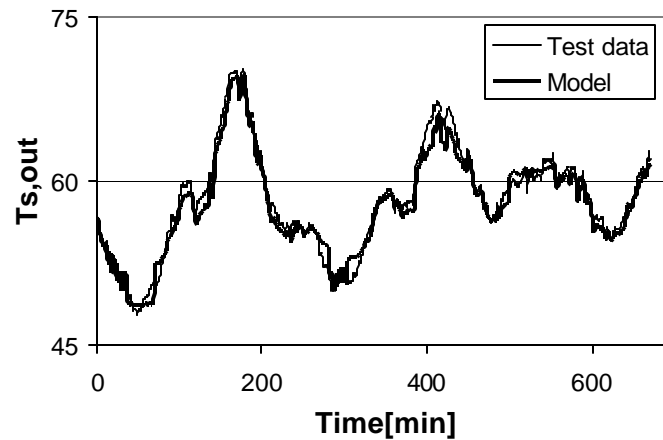

Figure 17. The model 1 output vs. data output.

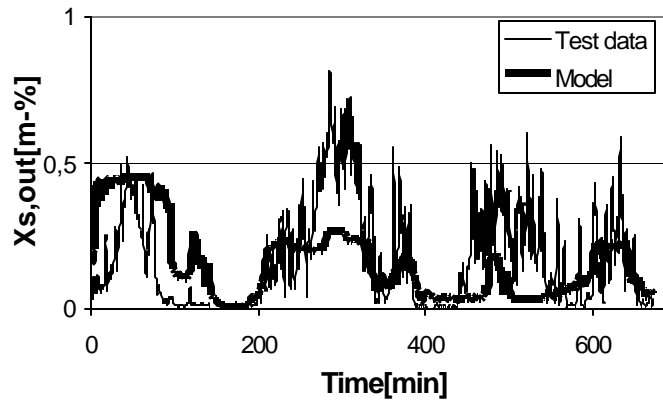

Figure 18. The model 2 output vs. data output.

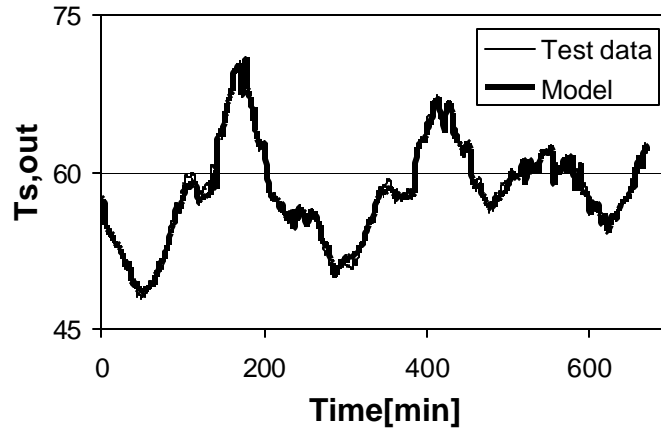

Figure 19. The final model 1 vs. data output.

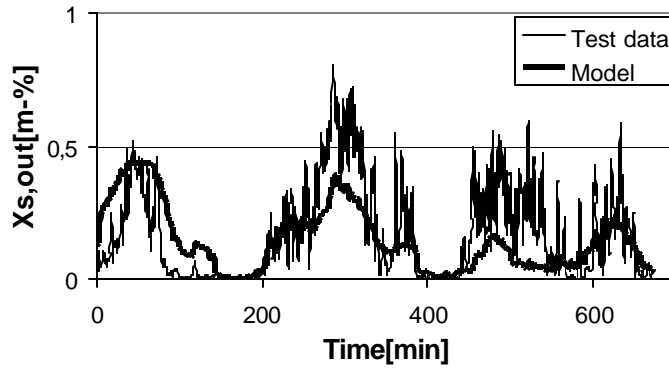

Figure 20. The final model 2 vs. data output.

Table 3. RMSE values for the final model.

Model	RMSE	
	$T_{s,out}$	$X_{s,out}$
Initial model	0.9981	0.1795
Final model	0.6343	0.1508

8 CONCLUSION AND FURTHER DEVELOPMENTS

We created a simple and effective fuzzy model of the rotary dryer. Firstly a comprehensive literature review has been presented and then the model is proposed. Two different structures are presented, the first structure achieved better results than the second, but had only one output. Ulterior optimisation loops can be done, and of course other optimisation methods can be applied.

In the future we will examine possibilities of improving the model by adopting the backpropagation-based approach, proposed by Wang and Mendel [21], to optimise the parameters α_{ij} and σ_{ij} .

This methodology can be used in conjunction with different criteria for model structure selection. It is also a fast method for generating fuzzy models based on neural network and fuzzy clustering techniques. Since this method focuses on model simplicity and computing efficiency for a satisfactory modelling accuracy, the produced model structure may not be optimal, but sub-optimal instead.

REFERENCES

- [1] Yliniemi L (1999) Advanced control of a rotary dryer. D.thesis, Univ Oulu.
- [2] Koskinen, J, Methods for Fuzzy Modeling of Rotary dryer, Proceedings of TOOLMET'99 Symposium-Tool Environments and Development Methods for Intelligent System, Oulu
- [3] Rauma,T (1999) Fuzzy modeling for industrial system, VTT Publications
- [4] Babuska, R. et al.(1999), Constrained parameter estimation in Fuzzy Modeling, IEEE International Fuzzy System Conference Proceedings.
- [5] Babuska, R. et al., Fuzzy modeling and Similarity Analysis Applied to Ecological Data, IEEE 97 pages 415-420
- [6] Salehfar, H. et al., A systematic approach to linguistic fuzzy modeling based on input-output data, IEEE Proceedings of the 2000 Winter Simulation Conference.
- [7] Castillo, O. and Melin, P. Modeling complex dynamical system with a new fuzzy inference system for differential equations: the case of robotic dynamic Systems, IEEE International Fuzzy System Conference Proceedings
- [8] Hwang, H.S. Automatic design of fuzzy rule base for modeling and control using evolutionary programming, IEE Proc-Control Theory Appl, Vol 146 ,1999.
- [9] Ali, Y.M. and Zhang, L. A methodology for fuzzy modeling of engineering systems, Fuzzy Sets and Systems 118 (2001) 181-197
- [10] Vachkov, G. and Fukuda, T. Multilevel composite fuzzy models, 2000 IEEE
- [11] Linkens, D.A. and Chen, M.Y. Input selection and partition validation for fuzzy modeling using neural network, Fuzzy Sets and Systems 107 (1999) 299-308
- [12] Park, M. et al., A new approach to the identification of a fuzzy model, FUZZY Sets and System 104 (1999) 169-181
- [13] Huang, Y.P. and Chu, H.C. Simplifying fuzzy modeling by both gray relation analysis and data transformation methods, Fuzzy Sets and Systems 104(1999) 183-197
- [14] Saéz, D. and Cipriano, A. Fuzzy modeling for a combined cycle power plant, 1999 IEEE International Fuzzy Systems Conference Proceedings
- [15] Skrjanc, I. and Matko, D. Predictive functional Control based on fuzzy model for heat-exchanger pilot plant, IEEE Transactions on Fuzzy Systems Vol.8, NO.6 December 2000
- [16] Juuso, E. et al., Linguistic equation applied to fuzzy modeling of rotary dryer, In Yliniemi, L & Juuso, E (ed.), Proceedings of TOOLMET'98-Tool environments and development methods for intelligent systems, University of Oulu.
- [17] Emami, M.R Turksen, Burhan. Goldenberg A.A.. Development of A Systematic Methodology of Fuzzy Logic Modeling, IEEE Transactions on Fuzzy Systems, 6(3).
- [18] Sugeno, M., and Takahiro Yasukawa, 1993. A Fuzzy Logic-Based Approach to Qualitative Modeling, IEEE Transactions on Fuzzy Systems, 1(1): 7-31.
- [19] Windham, M, Cluster validity for the fuzzy c-means clustering algorithm, IEEE Transactions on Pattern Analysis and Machine Intelligence PAMI a, 357-363(1982)
- [20] Bezdek, J.C., Pattern Recognition with Fuzzy objective Function Algorithms, New York, Plenum Press.,256p.(1981)
- [21] L.X. Wang, J.M. Mendel, Backpropagation fuzzy system as nonlinear dynamic system identifiers, in: Proc. 1st IEEE internat.Conf. on Fuzzy System, San Diego, CA 1992, pp.1409-1418.